

NOTES:  
 -TYPICAL SWALE LONGITUDINAL SLOPE 0.5-6%  
 -CHECK DAMS REQUIRED ON SLOPES > 3%  
 -SWALE LENGTHS SHOULD BE >5M FOR MAINTENANCE PURPOSES  
 -MIN. 50MM FREEBOARD  
 -ROUNDED SHOULDERS

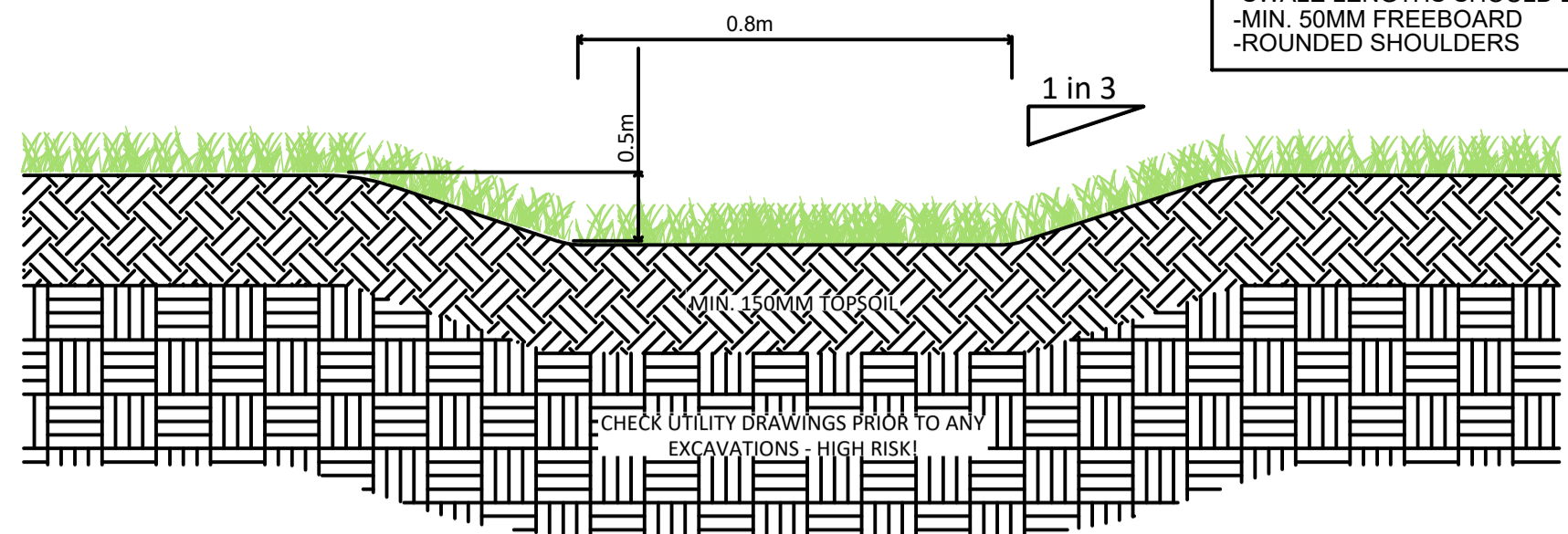

TYPICAL SHALLOW SWALE DETAIL  
 Scale: N.T.S

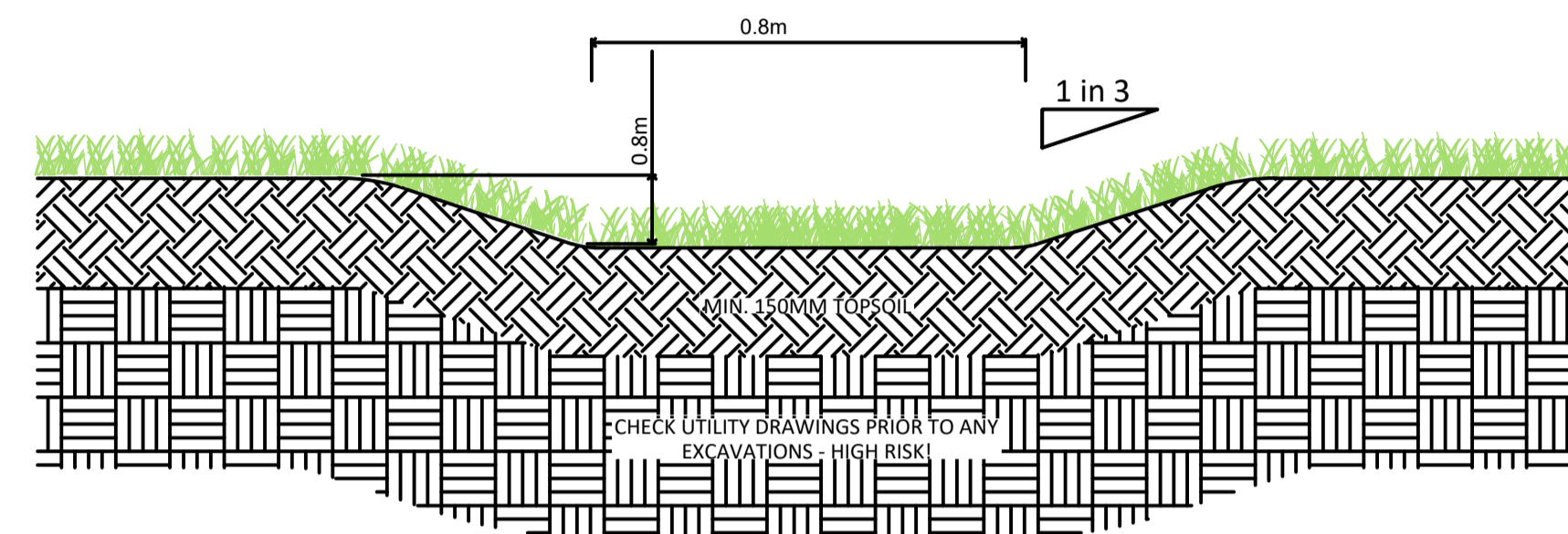

TYPICAL DEEP SWALE DETAIL  
 Scale: N.T.S

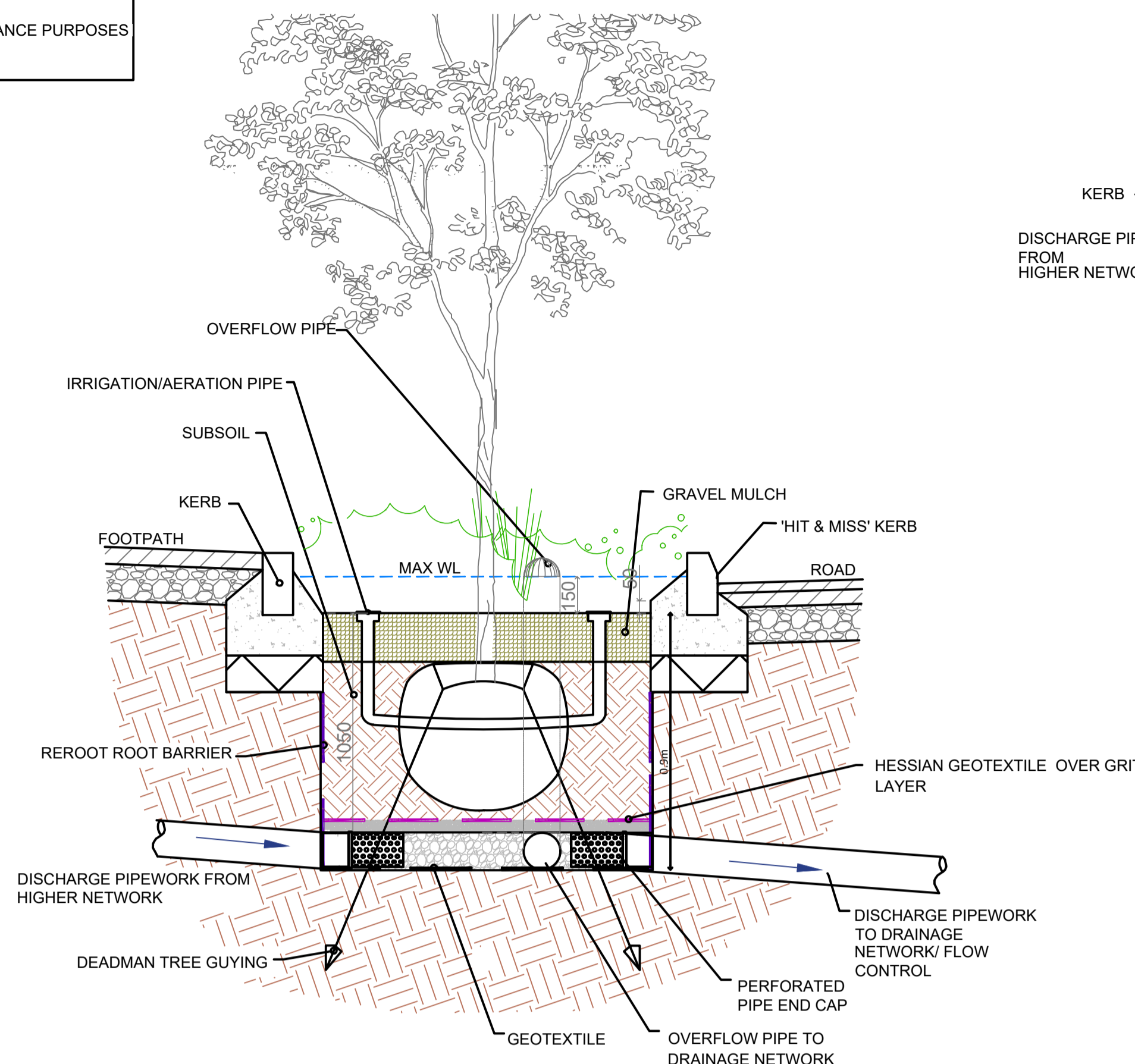

TYPICAL SECTION THROUGH TREE PIT BIORETENTION  
 Scale: N.T.S

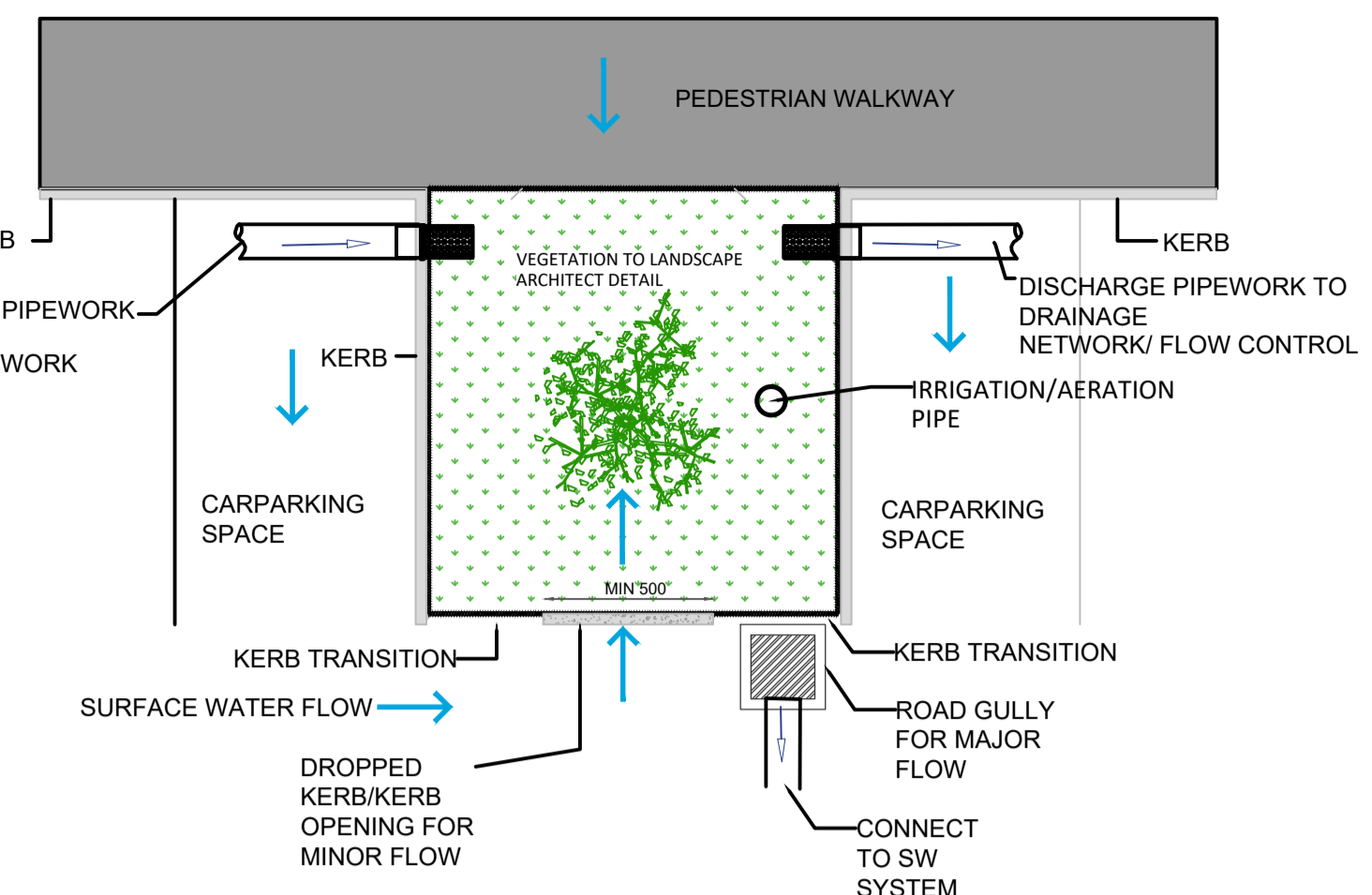

TYPICAL PLAN VIEW FOR TREE PIT BIORETENTION  
 Scale: N.T.S

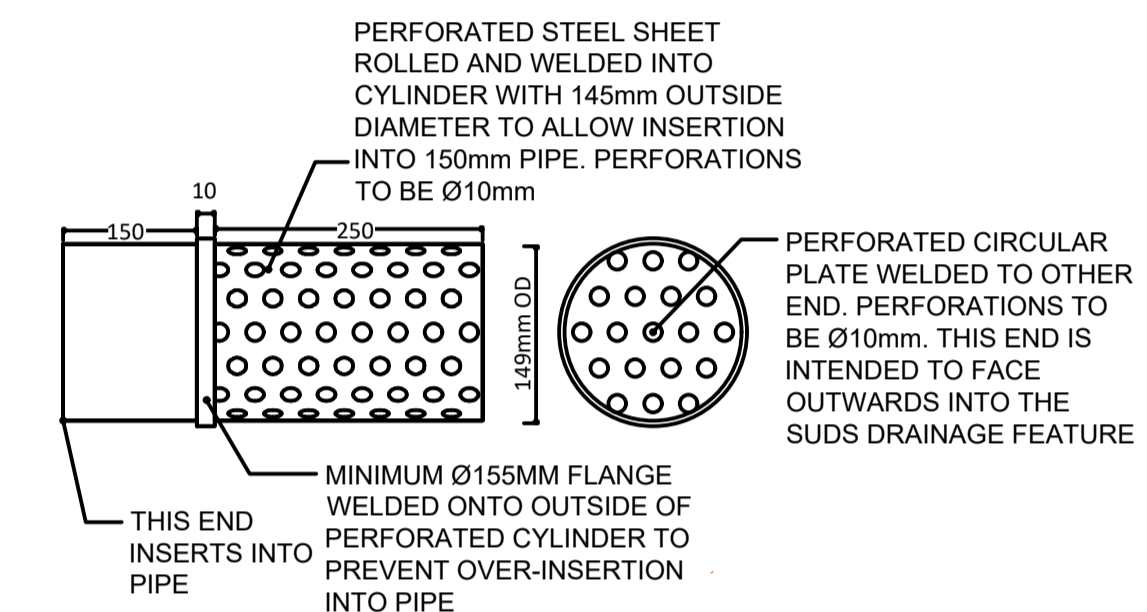

PERFORATED DRAINAGE END CAP (150mmØ PIPES)  
 Scale: N.T.S

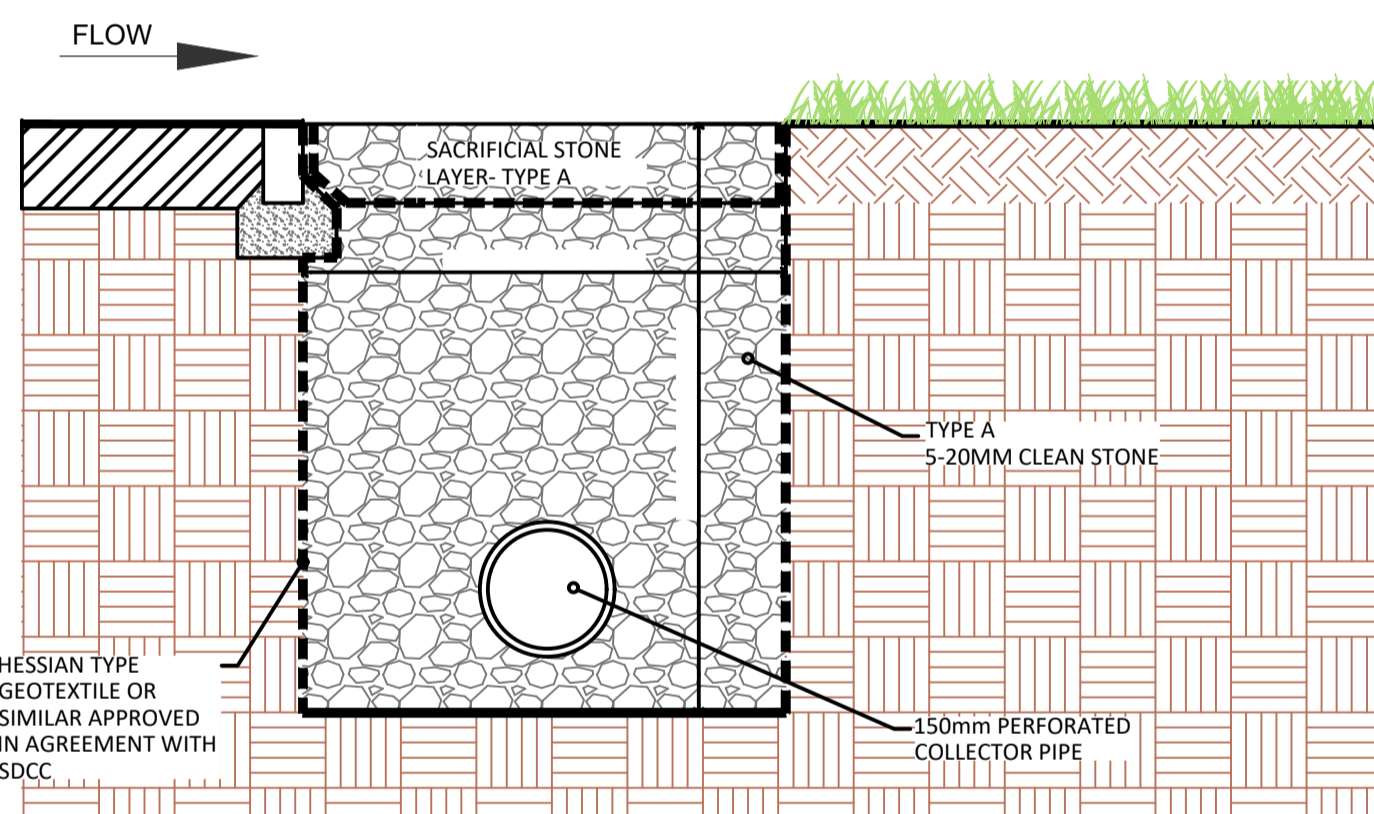

LAND DRAIN WITH COLLECTOR PIPE  
 Scale: N.T.S

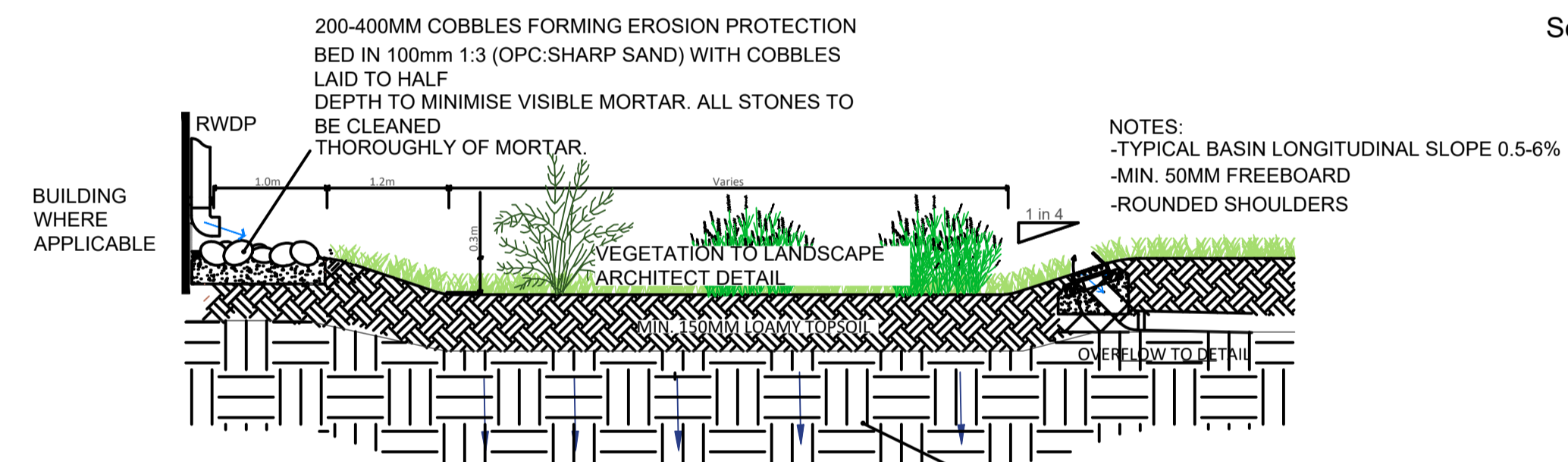

300mm DEEP RAIN GARDEN DETAIL  
 Scale: N.T.S

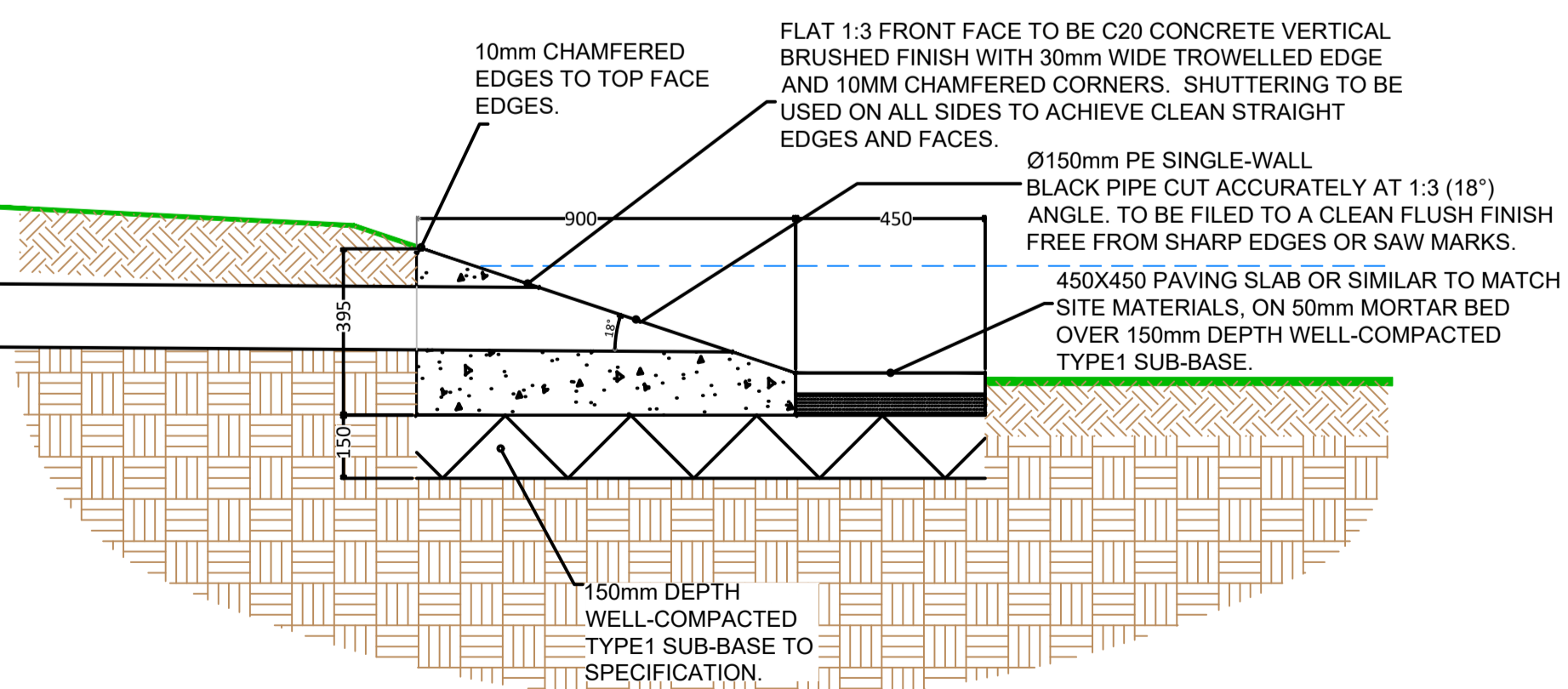

MITRED CONCRETE HEADWALL SECTION  
 Scale: N.T.S

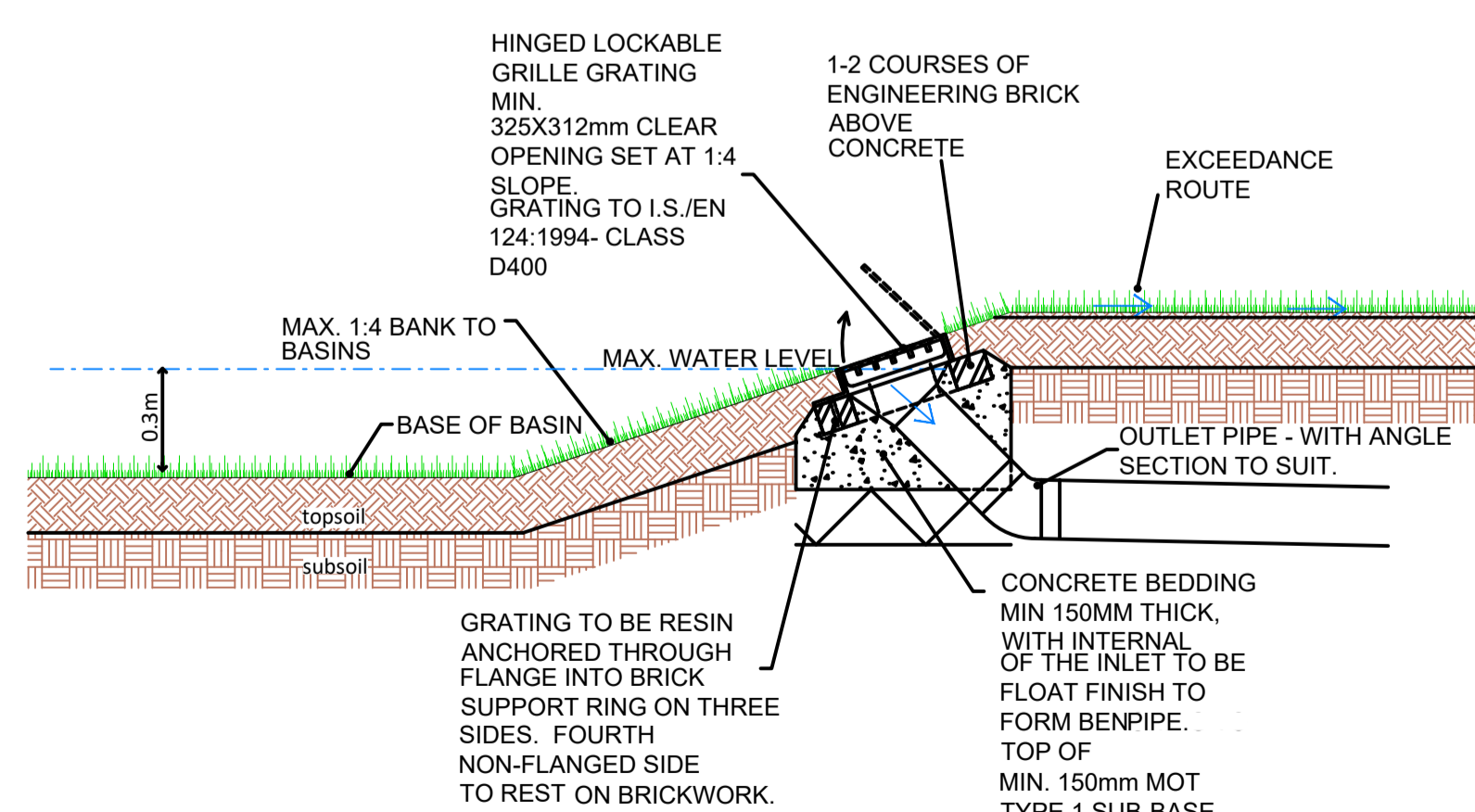

TYPICAL RAIN GARDEN OVERFLOW GRATING OUTLET DETAIL  
 Scale: N.T.S

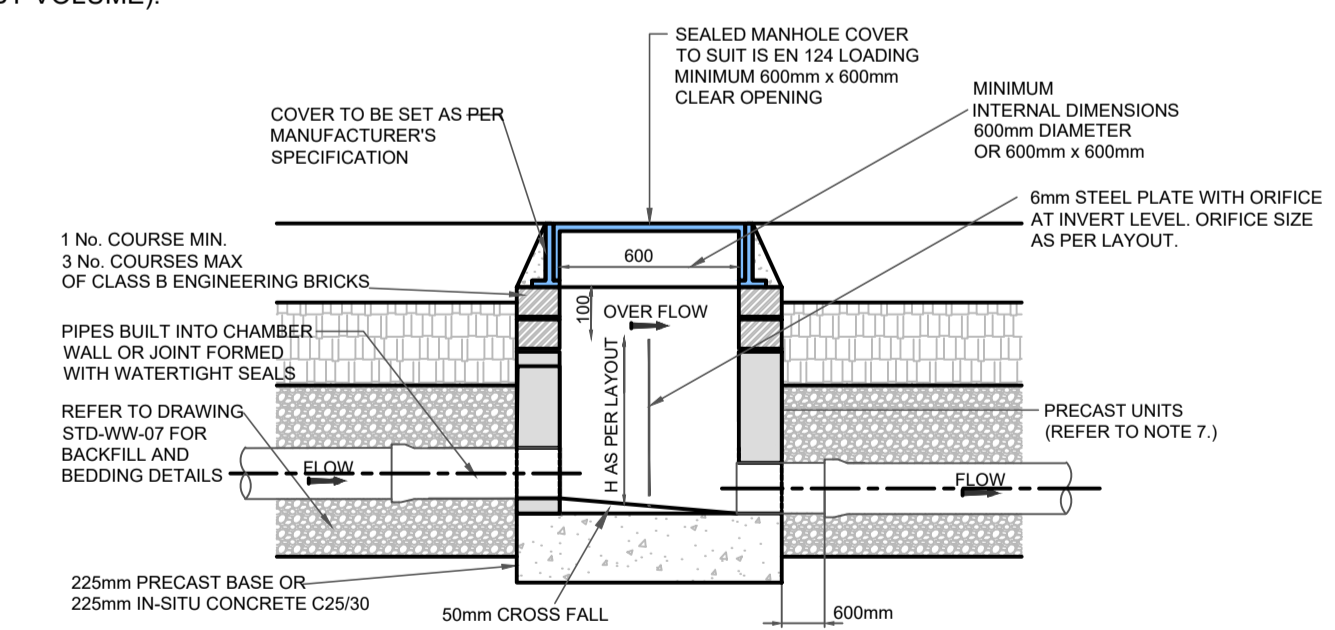

SECTION

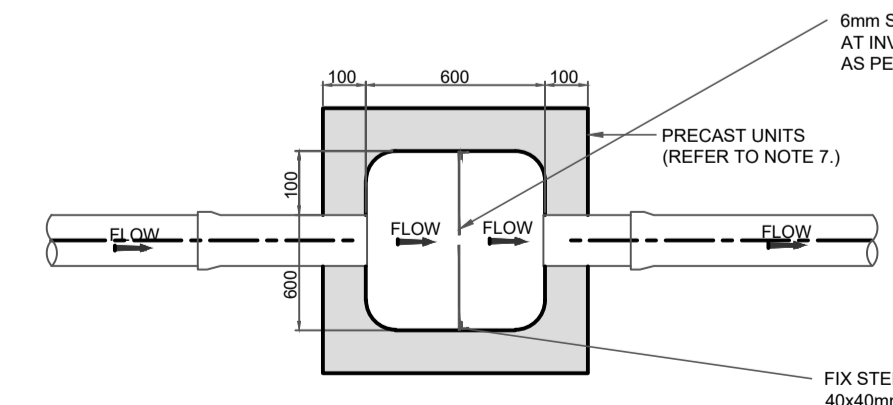

PLAN

PRECAST MANHOLE WITH ORIFICE BASE PLATE FOR FLOW CONTROL  
 Scale: N.T.S

GENERAL NOTES

- DO NOT SCALE THIS DRAWING. WORK ONLY TO FIGURED DIMENSIONS.
- FOR ALL RELEVANT NOTES, REFER TO STRUCTURAL AND CIVIL ENGINEERING PERFORMANCE SPECIFICATION.
- ANY DISCREPANCIES ARE TO BE REPORTED TO PINNACLE CONSULTING ENGINEERS IMMEDIATELY.
- THIS DRAWING IS TO BE READ IN CONJUNCTION WITH ALL OTHER RELEVANT ENGINEERS, ARCHITECTS AND SUB-CONTRACTORS DRAWINGS AND DETAILS.
- THIS DRAWING IS TO BE PRINTED IN COLOUR.
- THIS DRAWING IS NOT TO BE USED FOR CONSTRUCTION PURPOSES UNLESS EXPRESSLY STATED.
- EXISTING SITE AND LEVEL INFORMATION TAKEN FROM LAND SURVEYS TOPOGRAPHICAL SURVEY DRAWING D17282D DATED 04/10/06.
- THIS DRAWING HAS BEEN PREPARED USING THE PROPOSED SITE LAYOUT FROM DAVEY + SMITH ARCHITECTS DRAWING-IP00 DATED 16/08/24.

|     |                     |      |         |          |
|-----|---------------------|------|---------|----------|
| P01 | ISSUED FOR PLANNING | FJVR | JB      | 02/09/24 |
| REV | DESCRIPTION         | BY   | CHK/APP | DATE     |

CLIENT  
**CAPAMI LTD**

PROJECT  
**OLDCOURT LRD**

DRAWING TITLE  
**SUDS TYPICAL DETAILS SHEET 1 OF 3**



GROSVENOR COURT,  
 67A PATRICK STREET,  
 DUN LAOGHAIRE,  
 COUNTY DUBLIN,  
 IRELAND, A96 W317  
 NORWICH WELWYN GARDEN CITY LONDON THE HAGUE FRANKFURT  
 TELEPHONE: +353 1 2311041

|                                 |            |          |         |          |
|---------------------------------|------------|----------|---------|----------|
| DRAWING STATUS                  |            |          |         |          |
| <b>PLANNING</b>                 |            |          |         |          |
| SCALE @ A1                      | DATE       | DRAWN BY | CHECKED | APPROVED |
| NTS                             | 2024/04/28 | FJVR     | JB      | SOR      |
| DRG NO.                         | REV.       |          |         |          |
| P211102-PIN-XX-XX-DR-C-00620-S2 | P01        |          |         |          |